

CUTLIST FOR ARTS AND CRAFTS SIDE TABLE

PART	MATERIAL	QTY	DIMENSIONS*
Top	White Oak	1	18 round x 1 thick
Leg	White Oak	4	1 1/2 square x 20 tall
Upper stretcher	White Oak	2	14 1/2 x 3/4 x 1
Lower stretcher	White Oak	2	16 1/2 x 2 1/2 x 1
Dowel	Ebony	4	1/4 round x 2

*ALL MEASUREMENTS IN INCHES.

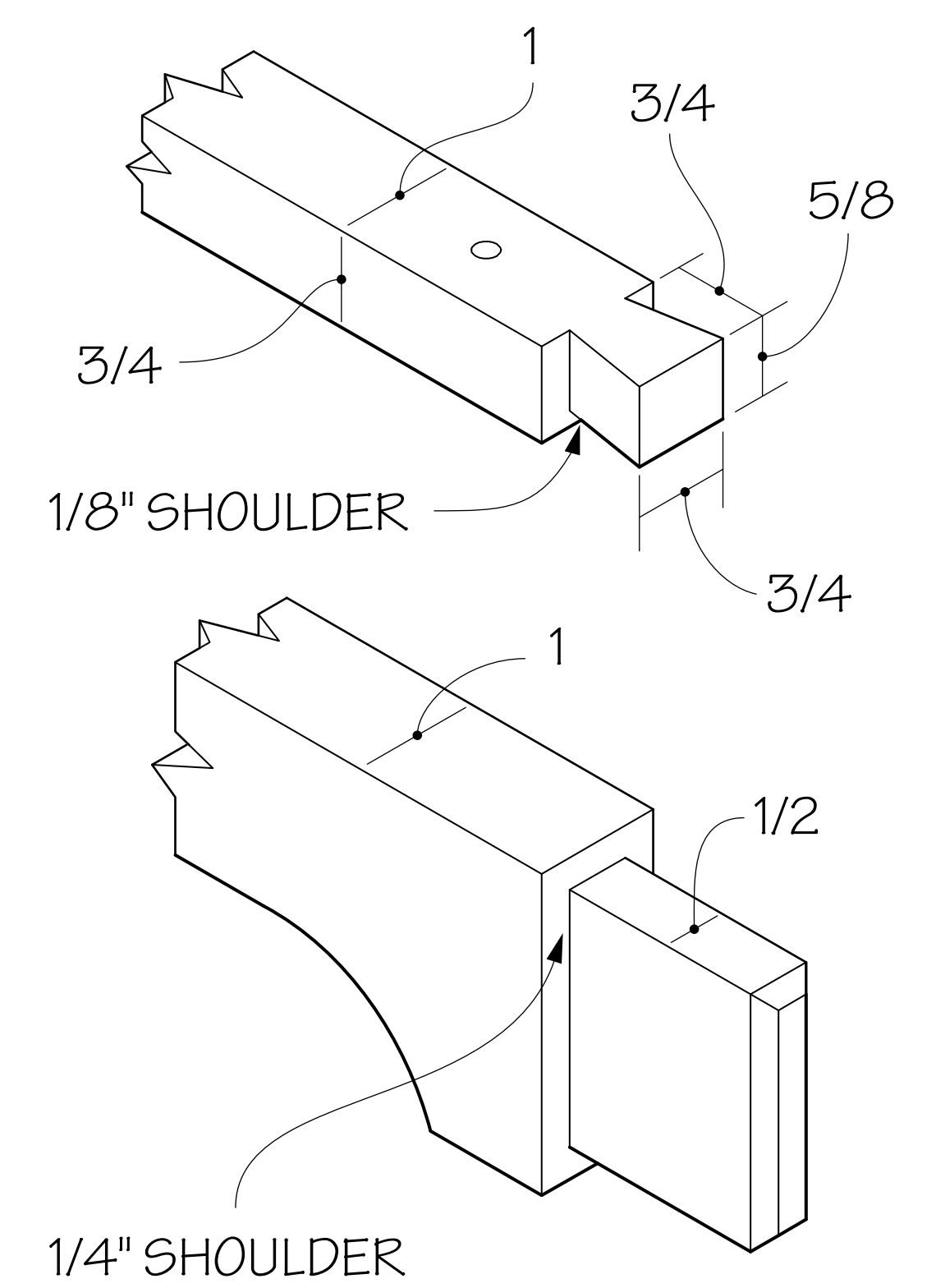
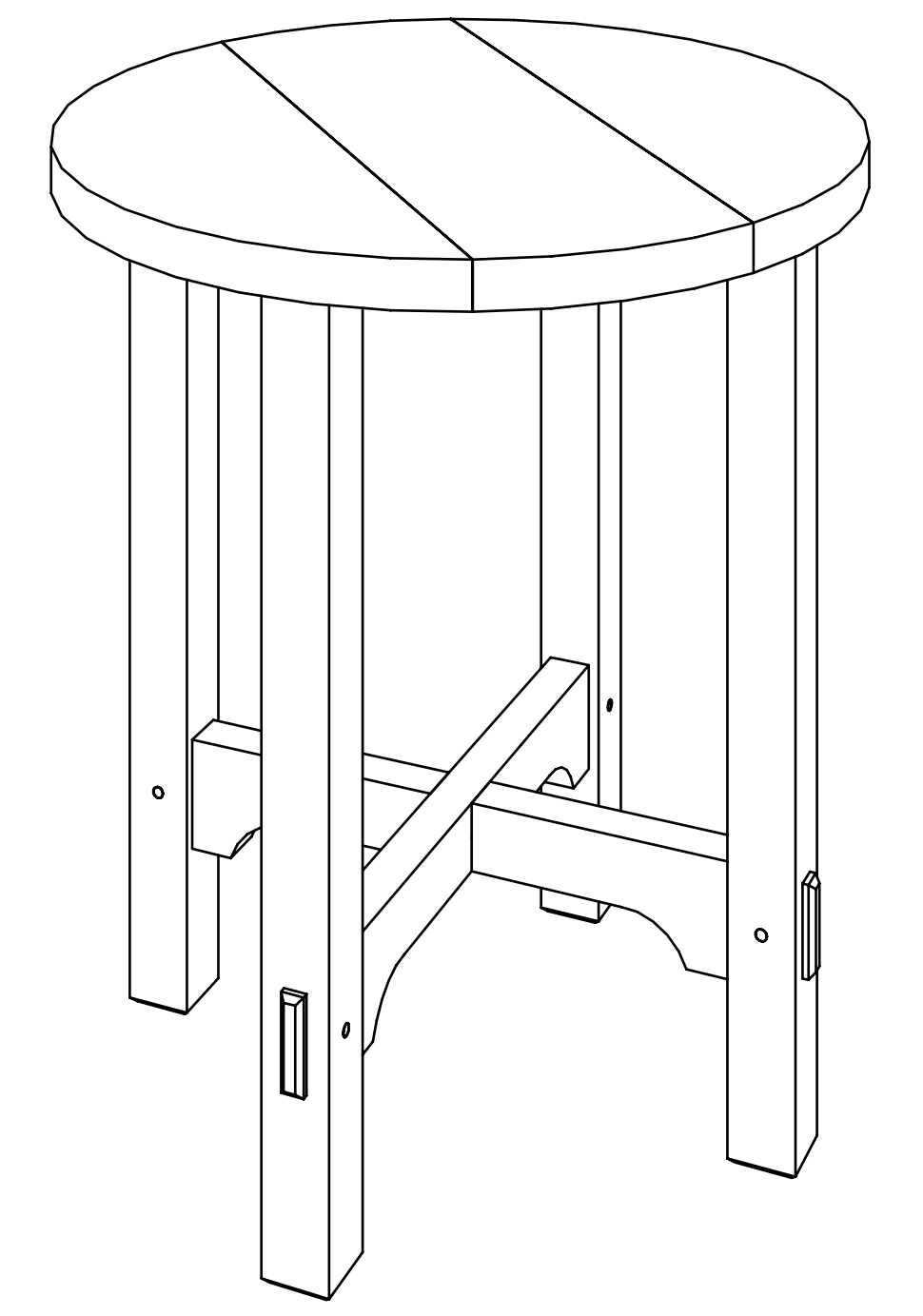
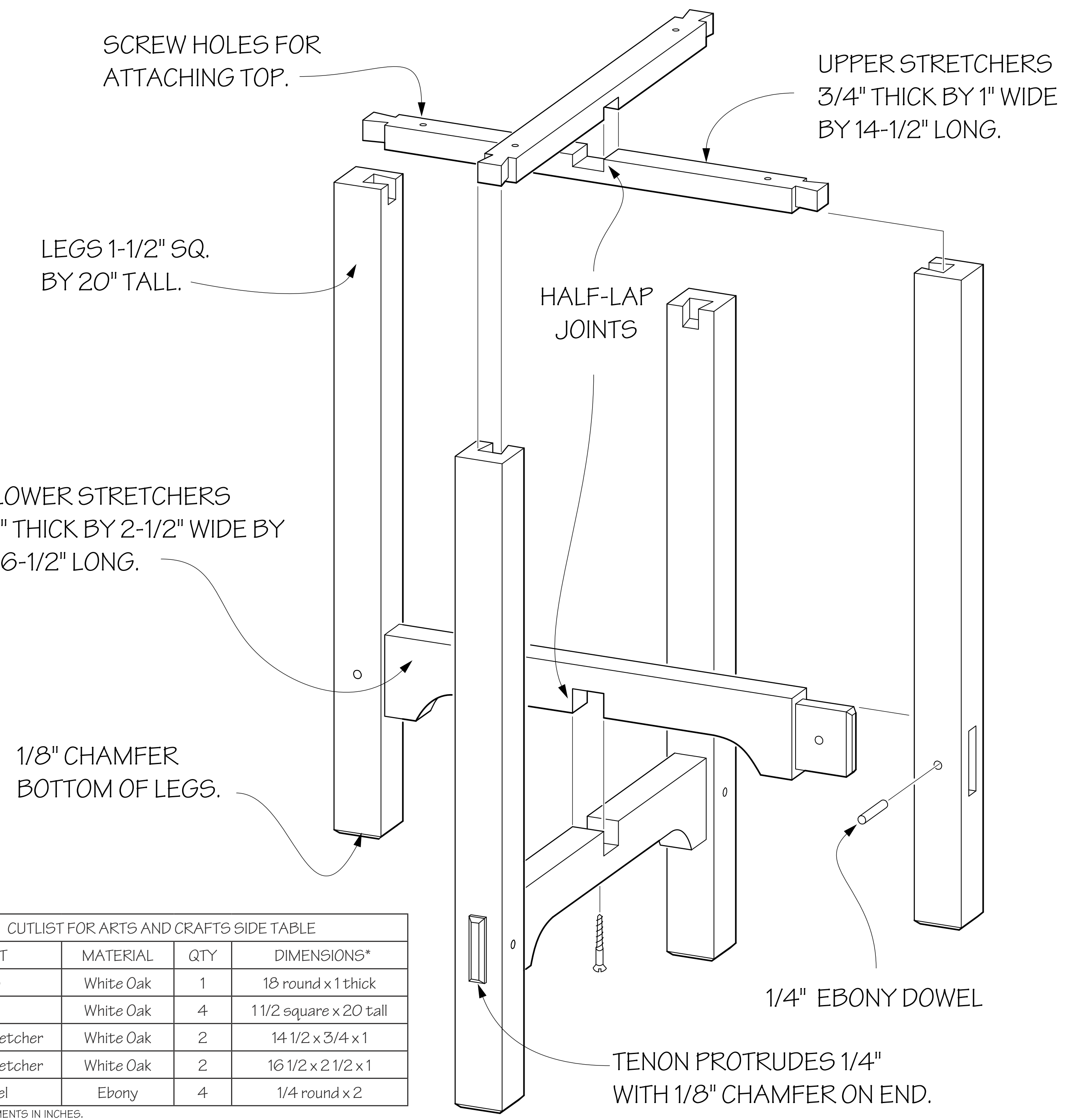
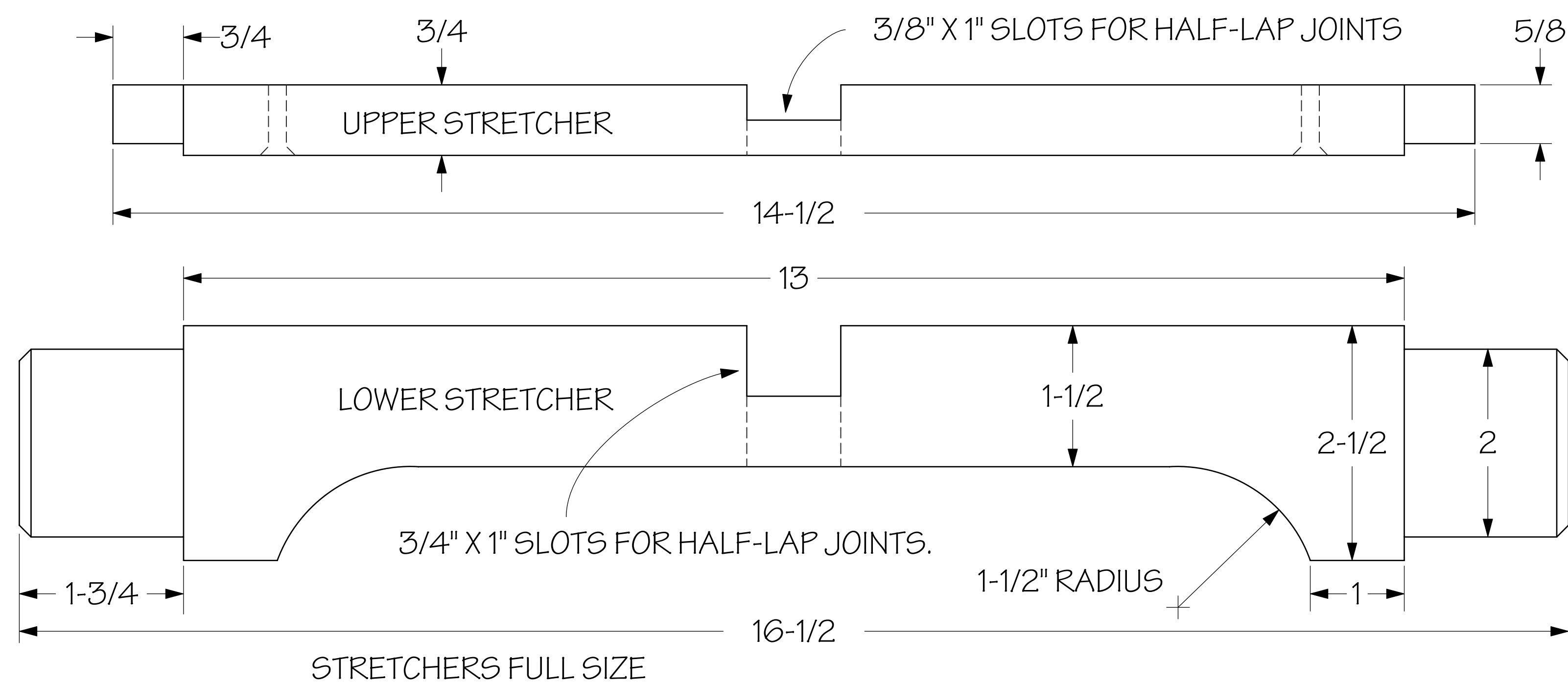

Fine
WoodWorking

A&C SIDE TABLE
DESIGN: KELLY DUNTON
DRAWING: JOHN HARTMAN
DATE: 2006